



Abbildungen/Daten/Diagramme unverbindlich
Illustrations/Dates/Graphs without engagement

Drehschieberpumpe für nicht

- giftige
- brennbare
- explosive Gase

Rotary vane pump for non

- toxic
- flammable
- explosive gases

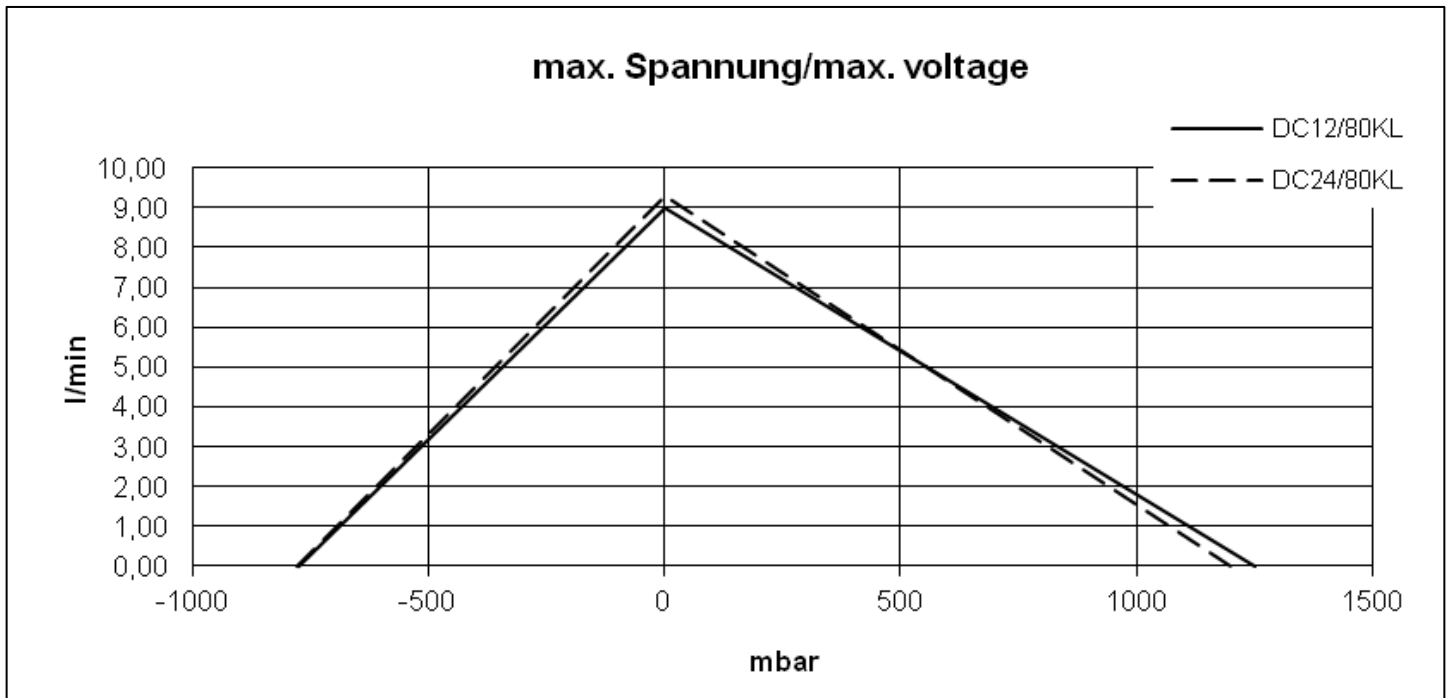

Typ/Model	Gewicht weight kg	Nennstrom Nominate current A	Spannung voltage V	Volumenstrom flow l/(min)	Vakuum vacuum			Druck pressure				
					Strom current		[-] mbar	Lautstärke noise level dB(A)	Strom current		[+] mbar	Lautstärke noise level dB(A)
					min. A	max. A			min. A	max. A		
DC12/80KL Art.-Nr.: 16001	0,69	2,0	12,0	8,9	1,4	2,3	775	78	1,4	4,3	1250	81
			9,0	6,6	1,2	2,2	750	74	1,2	3,3	930	73
			6,0	4,2	0,9	1,8	525	66	0,9	2,2	550	64
DC24/80KL Art.-Nr.: 16101		1,0	24,0	9,3	0,7	1,3	780	81	0,8	2,2	1200	72
			18,0	6,8	0,6	1,2	720	77	0,7	1,8	950	67
			12,0	4,4	0,5	1,0	540	70	0,5	1,2	580	58
Art.-Nr.:												
Art.-Nr.:												

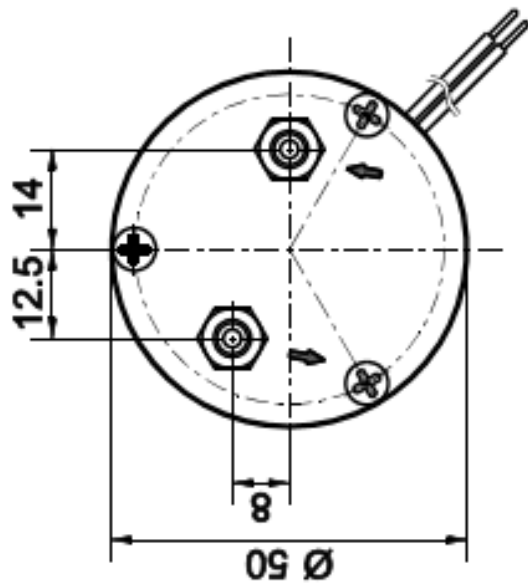

Litzen
 AWG 18 UL - Style 1569
 schwarz / rot
 L=300 +/-30 ab Flansch
 Litzenenden 7 +/-1mm
 abisoliert und verzinkt

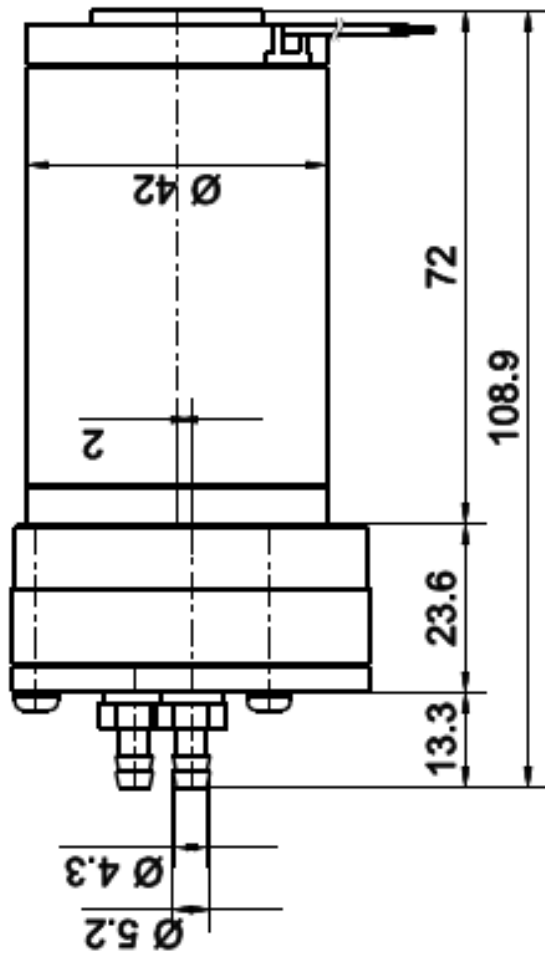

Fürgut GmbH Lärchenweg 12 D-49459 Tuisshalle Tel. 08395 936333 Fax 08395 936204		Unterverleite Maße ISO 2768-m		Material: Benennung: Vakuumpumpe DC 12 / 80KL Vacuum pump	
		Datum 22.10.2018	Name R. Fürgut	Zeichnung: 1:1 Maßstab	
		Ersteller Geprüft X X	R. Fürgut X		
Index	Änderung	Datum	Name		

Type/Model: DC12/80KL

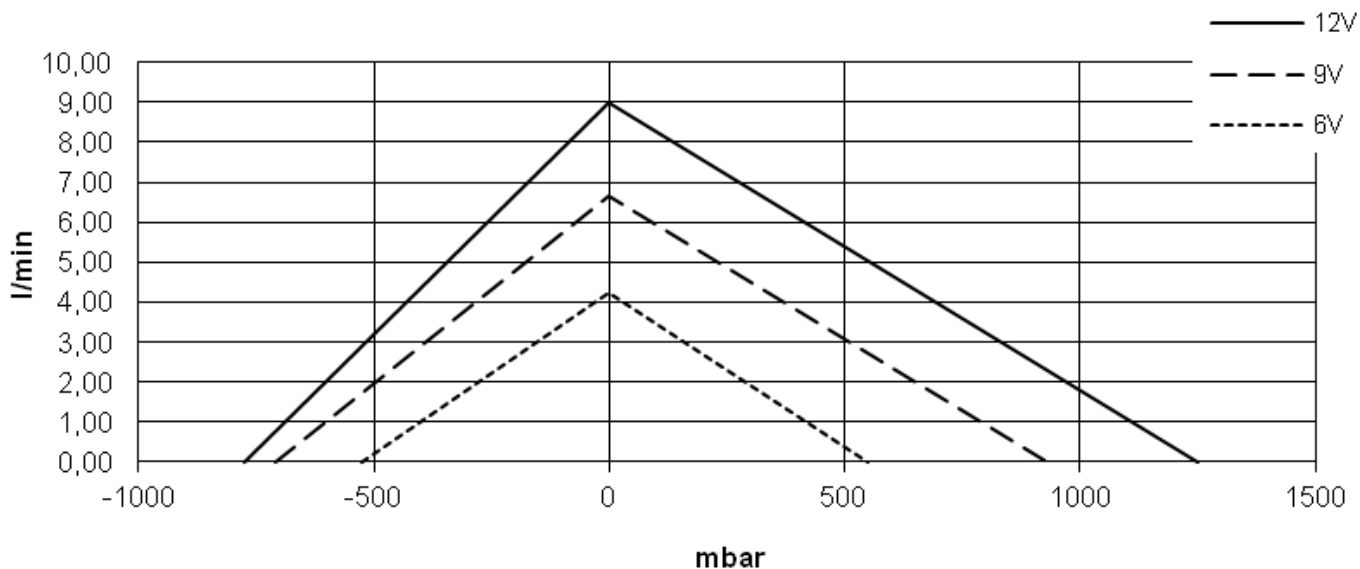

Type/Model: DC24/80KL

