



Abbildungen/Daten/Diagramme unverbindlich
Illustrations/Dates/Graphs without engagement

Drehschieberpumpe für nicht

- giftige
- brennbare
- explosive Gase

Rotary vane pump for non

- toxic
- flammable
- explosive gases

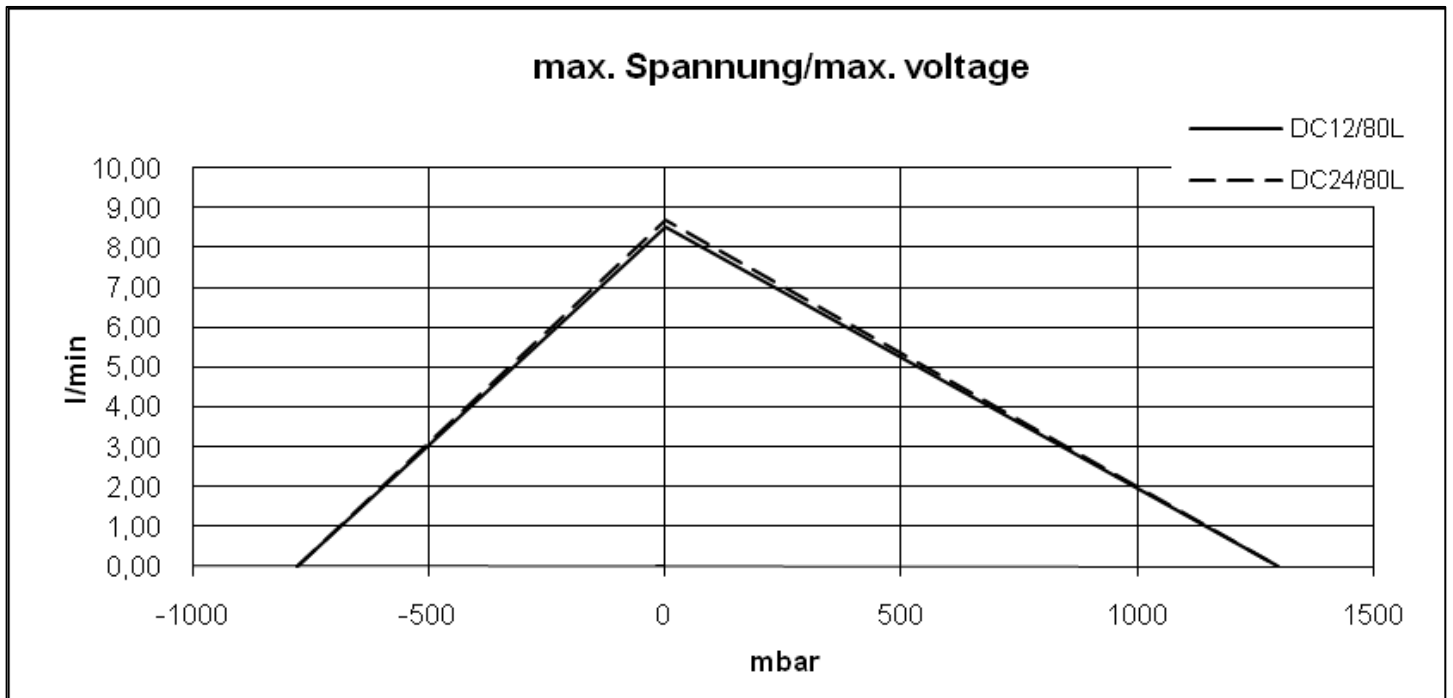

Typ/Model	Gewicht weight kg	Nennstrom Nominate current A	Spannung voltage V	Volumenstrom flow l/(min)	Vakuum vacuum			Druck pressure				
					Strom current		[-] mbar	Lautstärke noise level dB(A)	Strom current		[+] mbar	Lautstärke noise level dB(A)
					min. A	max. A			min. A	max. A		
DC12/80L Art.-Nr.: 15982	0,69	1,9	12,0	8,5	1,4	2,0	780	78	1,3	4,3	1300	81
			9,0	6,1	1,1	1,9	750	74	1,1	3,3	900	73
			6,0	3,9	0,8	1,6	600	66	0,8	2,1	600	64
DC24/80L Art.-Nr.: 16984		0,9	24,0	8,6	0,6	1,0	780	81	0,6	2,1	1300	72
			18,0	6,1	0,5	1,0	700	77	0,5	1,8	900	67
			12,0	4,4	0,4	0,8	540	70	0,4	1,1	600	58
Art.-Nr.:												
Art.-Nr.:												

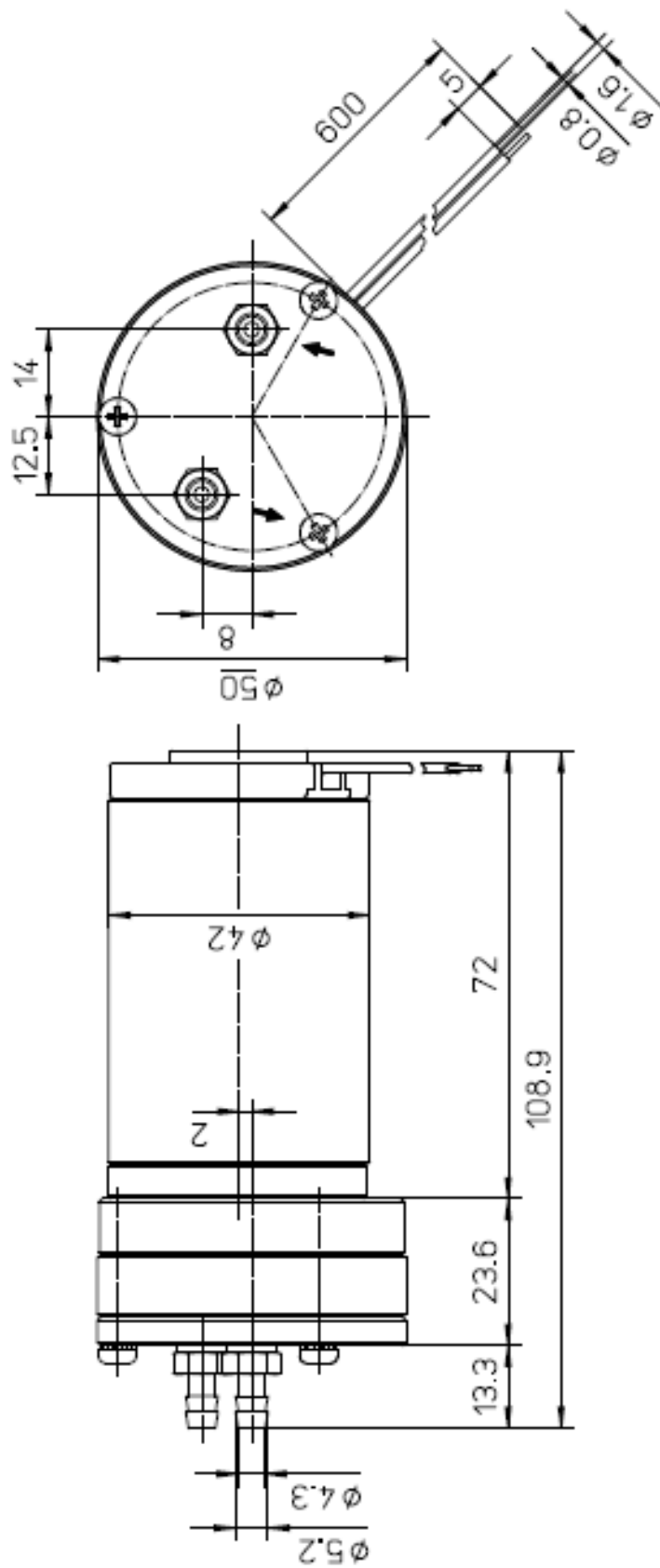

Fürgut GmbH Lärchenweg 12 D-88459 Tannheim Tel. 08395 936633 Fax 08395 936634	Umstülpte Maße Oberfläche		Material	
	ISO 2768-m			
	Datum	Notiz	Benennung	
	Ersteller	De Giacomo	Vakuumpumpe DC 12 / 80 L	
	Geprüft		Vacuum pump	
			Zeichnung:	
			1:1	
Index	Aenderung	Datum	Maßstab	

Type/Model: DC12/80L

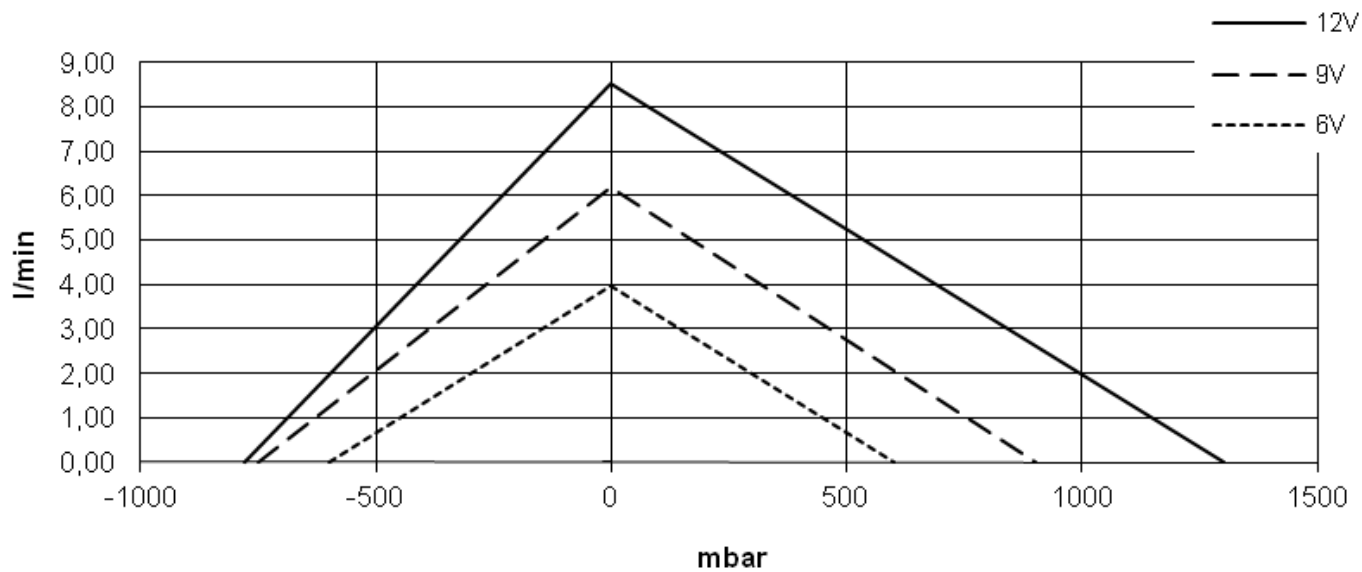

Type/Model: DC24/80L

